



# 1500 GALLON PRECAST GREASE INTERCEPTOR

Created: September 6, 2011

Revised: May 19, 2015

Scale: N.T.S.

Approved: May 19, 2015

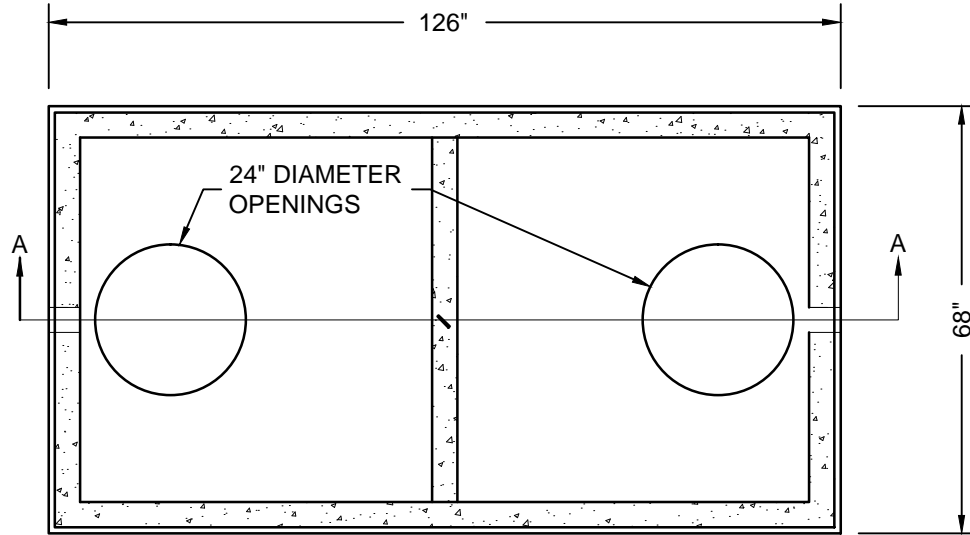

TOP VIEW

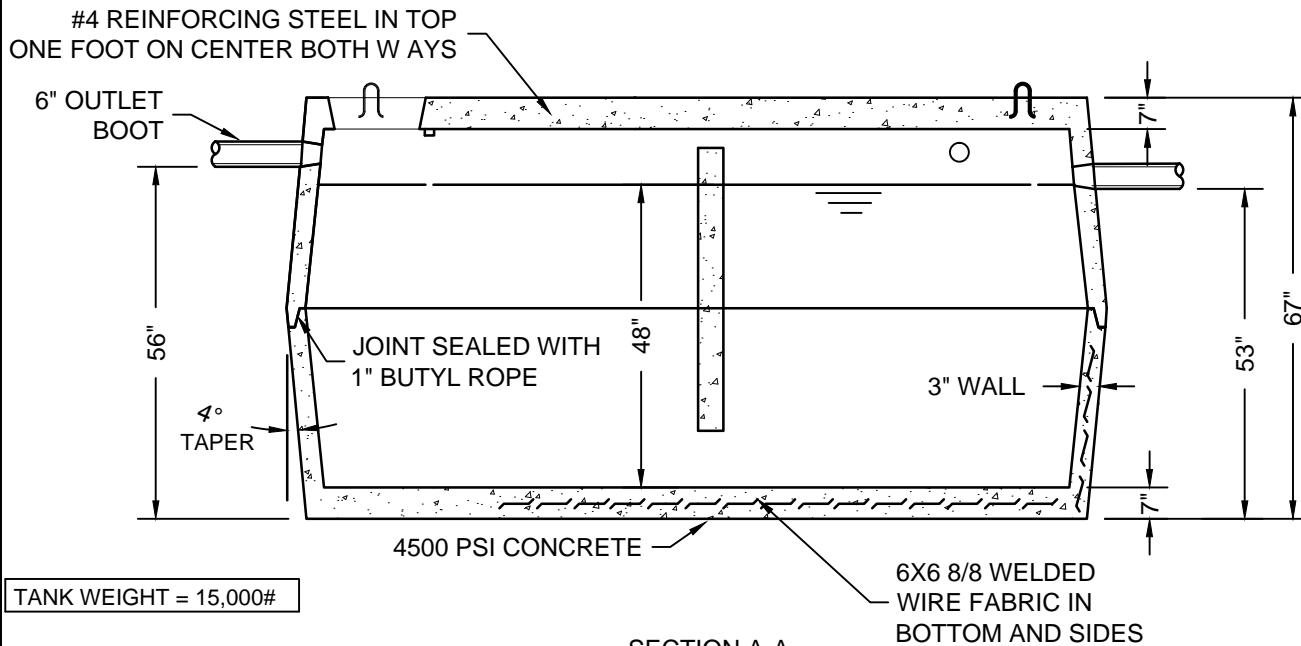

SECTION A-A

**NOTES:**

1. RISER RINGS SHOULD BE ORDERED TO GRADE.
2. MINIMUM 4500 PSI AT 28 DAYS CONCRETE.
3. REINFORCING BARS SHALL CONFORM TO ASTM A-615 GRADE 60 STEEL.
4. ALL REINFORCING BARS SHALL BE CUT AND FORMED TO THE DIMENSIONAL TOLERANCES SPECIFIED IN ACI-315 OR ACI-318 EXCEPT WHERE NOTED ON DRAWINGS.
5. ALL BARS SHALL BE BENT COLD. BARS WITH KINKS AND BENDS NOT INDICATED SHALL NOT BE USED. HEATING AND REBENDING OF BARS IS NOT PERMITTED.
6. REINFORCING STEEL SHALL BE #4 REBAR AT 12" O.C. ONE WAY OR 6X6 10/10 WELDED WIRE MESH.
7. EARTH COVER: 6" MINIMUM UP TO 3'-0" MAXIMUM. SIZE PAD ACCORDING TO AMOUNT OF EARTH COVER.