



WATER MAIN LOWERING

Created: April 22, 2016

Revised: JANURARY 4, 2018

Scale: N.T.S.

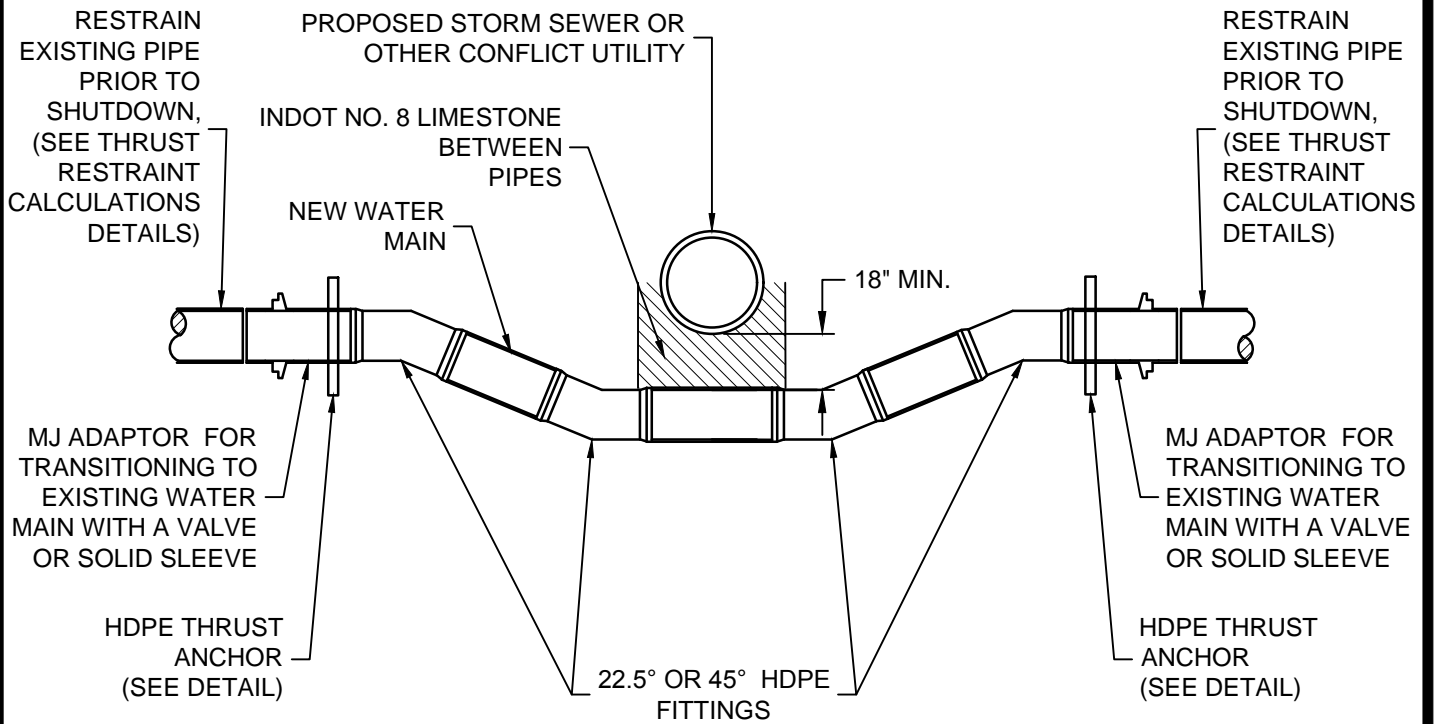

NOTES:

1. PIPE AND FITTING MATERIAL TO BE HDPE PRESSURE CLASS 200 RATED. USE MOLDED FITTINGS ON 6 AND 8 INCH MAINS.
2. TOTAL LENGTH OF LOWERING SHALL NOT EXCEED 40 FEET FOR A SWABBED DISINFECTION CONNECTION.
3. STAINLESS STEEL STIFFENERS AND MEGALUGS SHALL NOT BE USED ON HDPE; USE ELECTRO FUSION COUPLINGS OR BUTT FUSION.
4. FOR LOWERINGS LESS THAN 40 FEET IN LENGTH, OWNER MAY CONSIDER ELIMINATION OF THE HDPE THRUST ANCHOR ON A CASE BY CASE BASIS.